

Original silencers

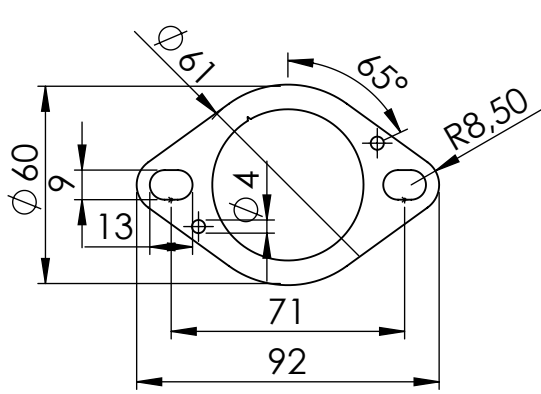

CILINDER FLANGE SP. 5mm
Cod. 206412

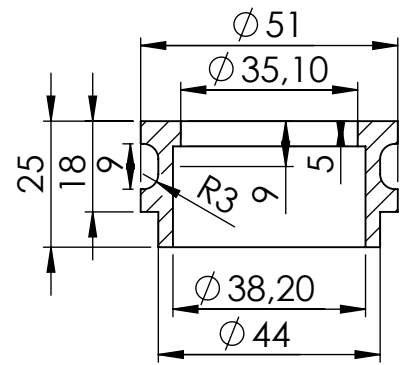

CILINDER BUSHING
Cod. 206413

Warning:
Headers pipes can be fitted with the stock silencer only

N°2 cylinder bushing
Aisi 304 SS
Purchase Cod.206413

Pipe N°1266
Cod.308097203

N°2 flange Aisi 304 SS
Purchase Cod. 206412

N°1 Pipe RHS N°1166
Cod.3014220202

N°1 Knurled collar nut M8
Cod.200298

N°3 Mounting plate M6
Cod.204664

M12X1,25
Optional
Cod.5683

1x Plain washer
8x24 Cod.200321

N°1 Allen screw
T.C.E.I. M8X40 Z.B.
Cod.200993

N°5 Short helical
spring tensile
Cod.303949001

N°1 Pipe 2/1 N°1216
Cod.3014273201

N°1 Pipe LHS N°1265
Cod.308097201

WARNING

it is advisable to optimize the carburation by remapping the stock ECU or by adopting an additional ECU unit.

ART. 8097

HONDA CRF 1000 L AFRICA TWIN / ADVENTURE SPORTS

(Compatible with stock exhaust only, not compatible with LeoVince slip-on)

HEADERS PIPES 2/1 - STAINLESS S.